

Hana

Anti-Scratch

DOUBLE KITCHEN SINK, 27L/27L

Features

- Treated with Nano technology for enhanced durability and scratch resistance
- Anti-condensation coating underneath the sink prevents mildew
- Hand made from 1.2 mm thick, high quality 304 stainless steel
- Fitted with sound and vibration dampening panels to reduce acoustic impact of water and equipment
- Two matching basket wastes included
- Topmount or undermount installation
- Mounting brackets and screws included
- Overall Size: 760 L x 450 W x 200 D mm

Optional Accessories

- Sink Protector (A24/A24CM)
- Roll Up Drainer (A22/A22CM)
- Chopping Board (A37)

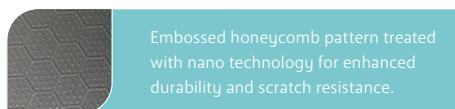

Embossed honeycomb pattern treated with nano technology for enhanced durability and scratch resistance.

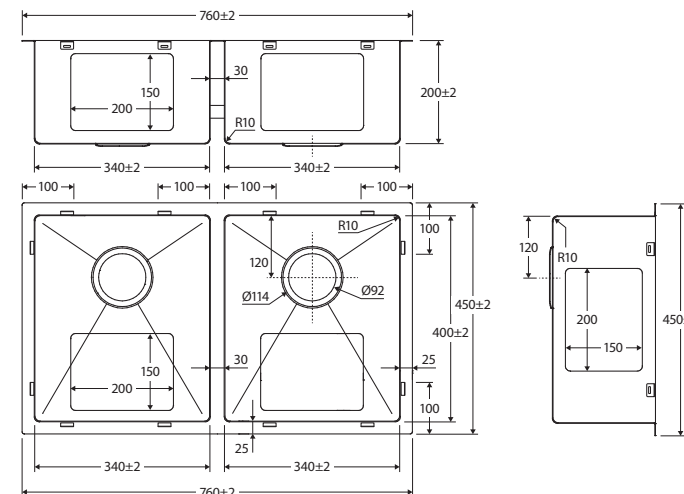

Available in



Brushed
Stainless Steel
68403AS



PVD
Gun Metal
68403ASGM

Cleaning & Care

- Dry off any water droplets after use with a clean dry cloth.
- Once a week use a detergent mixed with a small amount of ammonia and rub gently with a soft cloth. Rinse thoroughly with cold water after cleaning, then dry with a clean cloth.
- Do not use steel wool, abrasive cleansers or cleaning pads to clean your sink.
- Do not use chemical "silver cleaners", bleaches, or detergents containing chlorine or any of its derivatives.

We aim to ensure that specifications are correct at the time of publication. All measurements are shown in millimetres. Always use measurements of actual product received for final specification as the technical drawing may contain differences. Due to printing limitations, physical colour may vary from the image shown. Fienza reserves the right to make modifications without prior notice.