

# Projix Rail Shower 5 Function Chrome

Product Code: 166161

## Product Specifications.

<b>WELS rating</b>	WELS 3 Star 9.0L/min
<b>WELS Registration No.</b>	
<b>Warranty</b>	20 years – main brass body, wall elbow, shower arm, shower rail, PVC coated hose, showerhead, handpiece, slide bracket, diverter assembly, soap dish, and chrome plated finish 5 years - PVD and electroplate finishes 1 year - seals and labour
<b>Colour</b>	Chrome
<b>Finish</b>	Electroplated, painted ABS
<b>Installation Type</b>	Wall mount
<b>Material</b>	Brass Rail ABS Shower Rose, hand piece, soap dish and slider S/S Hose
<b>Shower Type</b>	Rail Shower
<b>Function</b>	5 function hand shower
<b>Rail Length</b>	695mm
<b>Rail Diameter</b>	25mm
<b>Hand Shower Diameter</b>	120mm



<b>Inclusions</b>	Rail Shower Soap dish Installation Instructions
<b>Maintenance &amp; Care</b>	Clean using a soft sponge or cloth with warm soapy water or detergent. Never use abrasive brushes or scourer pads to clean products. Rinse with water immediately after using any cleaning solution

For more information call 1800 BATHROOM (1800 228 476) or visit [raymor.com.au](http://raymor.com.au)

© Registered trademark of Tradelink. All dimensions are in millimetres. Dimensions are approximate and should be checked against the physical product before installation. Changes may be made to this specification without notice due to our commitment to continual improvement. See [raymor.com.au](http://raymor.com.au) for full warranty details.  
All dimensions in mm.

Version 1

**raymor**

# Projix Rail Shower 5 Function Chrome

Product Code: 166161

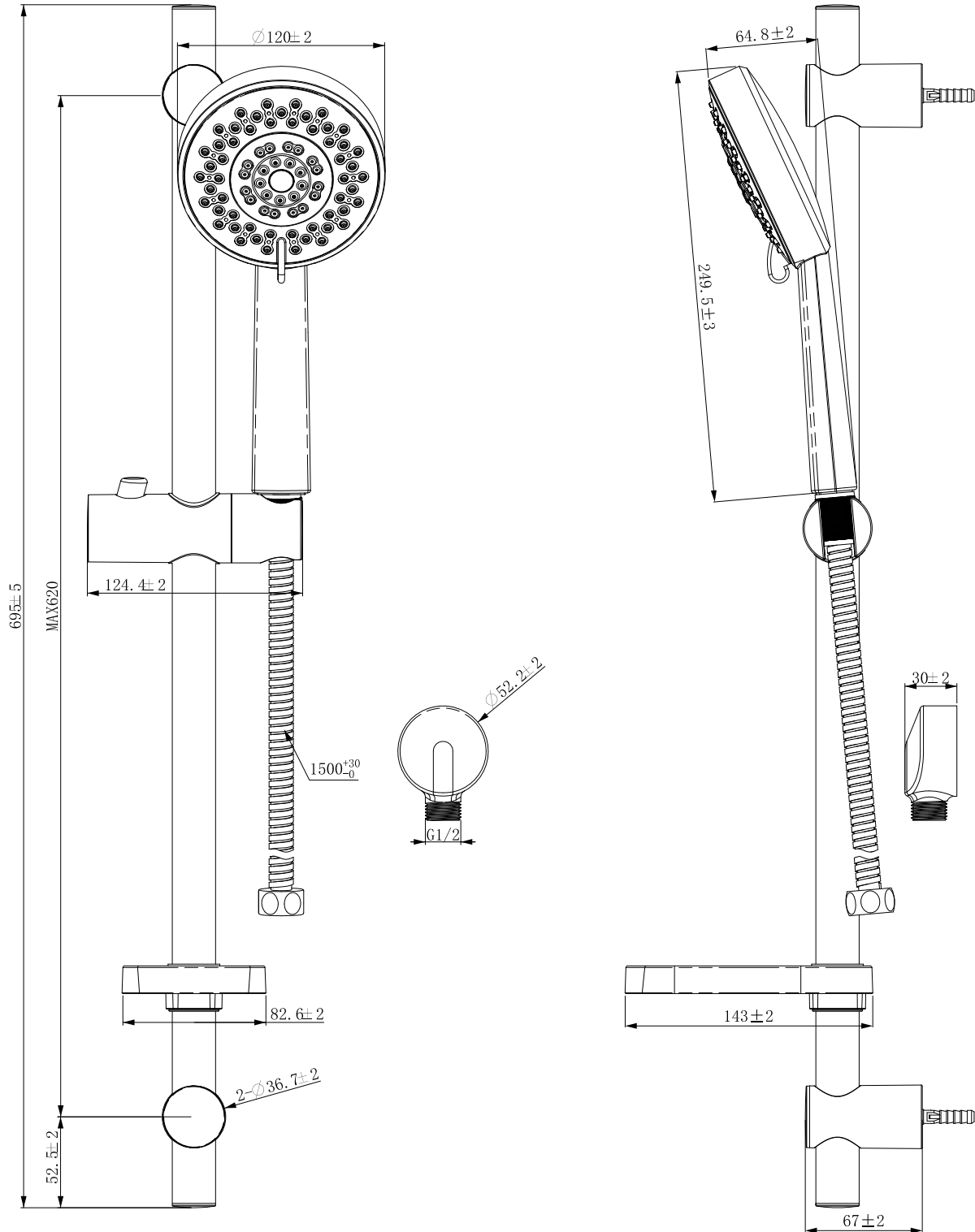

For more information call 1800 BATHROOM (1800 228 476) or visit [raymor.com.au](http://raymor.com.au)

© Registered trademark of Tradelink. All dimensions are in millimetres. Dimensions are approximate and should be checked against the physical product before installation. Changes may be made to this specification without notice due to our commitment to continual improvement. See [raymor.com.au](http://raymor.com.au) for full warranty details.  
All dimensions in mm.

Version 1

**raymor**